

Short Paper

Mixing Enhancement in a Microfluidic Device

Jin, Z.*¹, Someya, S.*², Okamoto, K.*² and Hu, H.*¹

*¹ Department of Aerospace Engineering, Iowa State University, Ames, Iowa, 50011, U.S.A.
E-mail: huhui@iastate.edu

*² Department of Human and Engineered Environmental Studies, the University of Tokyo, Kashiwanoha 5-1-5, Kashiwa-shi, Chiba 277-8563, Japan.

E-mail: some@k.u-tokyo.ac.jp, and okamoto@k.u-tokyo.ac.jp.

Received 2 July and Revised 3 November

1. Introduction

Two-fluid mixing is an essential process in many microfluidic or “lab-on-a-chip” devices for various biological and biochemical applications. Effective mixing of fluid streams inside microchannels could be very challenging since turbulence is usually absent due to the low Reynolds numbers (Yang, 2007). Odd et al. (2001) demonstrated for the first time that Electrokinetic instability (EKI) can be used to effectively enhance fluid mixing inside microchannels. EKI occurs when fluid streams with different electric conductivities meet under an applied electric field as shown schematically in Fig. 1. Several studies have been conducted recently to manipulate convective EKI waves to control fluid mixing in microchannels (Chen et al., 2005; Shin et al., 2005; Posner and Santigao; 2006). Although many important results have already been obtained through those previous studies, much work is still needed in order to establish a comprehensive database for the theoretic modeling and prediction of EKI and associated flow phenomena to explore/optimize design paradigms for the development of robust EKI micro-mixers for various applications. While most of the previous studies were conducted to investigate mixing of three streams in cross-shaped microchannels, EKI mixing process of two fluids in Y-shaped microchannels has not been explored. With the consideration of wide applications of two-fluid mixing and simple geometry of Y-shaped microchannels (Sugii et al., 2005), we conducted the present parametric study to elucidate underlying physics and to quantify the effectiveness of manipulating EKI waves to control/enhance fluid mixing inside a Y-shaped microchannel.

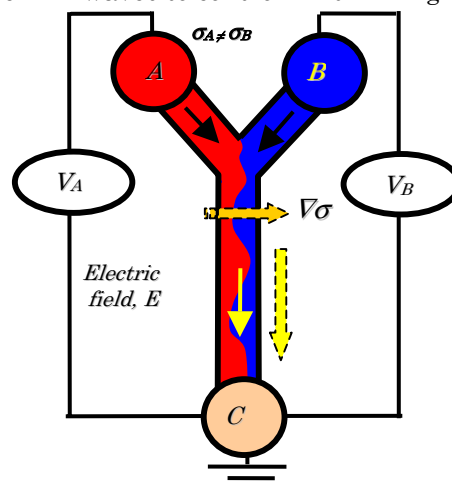

Fig. 1. Schematic of EKI.

2. Experimental Setup

Deionized water was used as the working fluid in the present study. Borate buffers were used to adjust the conductivity of the streams. Rhodamine B was used as the fluorescent dye for the flow diagnostics. Figure 2 shows the schematic of the experimental setup. The microchip with the Y-shaped microchannel was placed on the test bed of an inverted fluorescent microscope. A high-voltage power supply and a function generator with an amplifier were used to apply static voltage between the inlets and outlet of the microchannel. A high-resolution CCD camera with a 10X objective lens was used for the fluorescence imaging. A workstation with a digital delay generator was used for image acquisition, data storage and imaging processing.

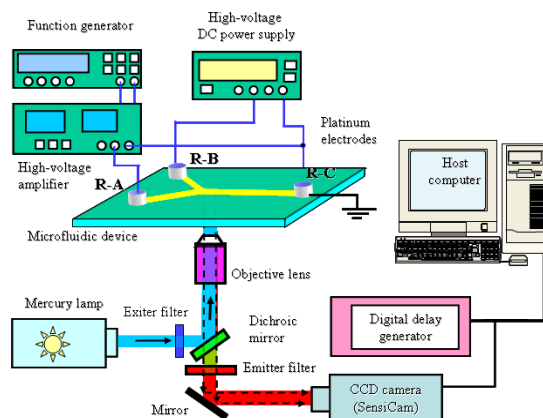
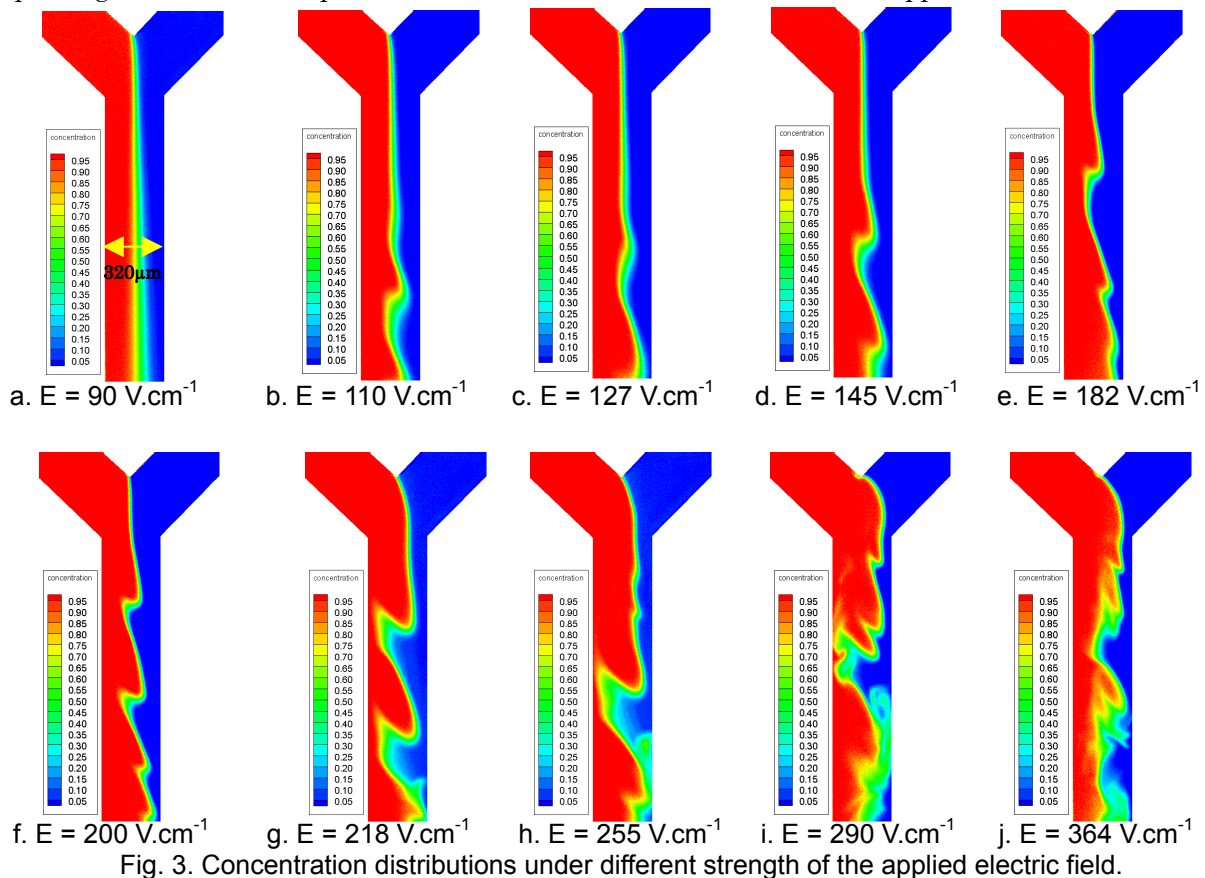

Fig. 2. Experimental setup.

3. Results and Discussions

Figure 3 shows examples of the measurement results of the present study, which are the typical instantaneous concentration distributions under different strengths of the applied static electric field. As visualized quantitatively in the figures, the interface of the two fluids was found to be straight and “clean” as the applied electric field is relatively weak (i.e., $E < 110 \text{ V.cm}^{-1}$). No noticeable fluctuations can be observed at the interface. Fluid mixing was confined in a very thin layer along the interface, and the mixing process is diffusion dominated. As the strength of the applied electric field becomes relatively stronger ($E > 110 \text{ V.cm}^{-1}$), observable convective EKI waves were found to shed periodically and propagate downstream along the interface of the mixing streams. The size of the convective EKI waves was found to increase rapidly as the strength of the applied electric field increases. When the strength of the applied electric field became $E > 200 \text{ V.cm}^{-1}$, additional smaller EKI waves were found to generate in the braid regions of the large EKI waves. After the generation of smaller EKI waves, the shedding process of the convective EKI waves was found to become much more random, and the interface of the mixing streams became much “dirtier” and fussier. When the strength of the applied electric field became higher than 250 V.cm^{-1} , the fluid mixing process was found to become much more turbulent and chaotic. The measurement results demonstrated clearly that the fluid mixing inside the Y-shaped microchannel can be enhanced effectively by manipulating the EKI waves. Such quantitative measurements are highly desirable to establish the comprehensive database to further our understanding about EKI and to explore/optimize design paradigms for the development of robust EKI micro-mixers for various applications.



References

- Chen, C. -H. et al., *J. Fluid Mech.*, 524 (2005), 263-303.
 Oddy, M. H. et al., *Anal. Chem.*, 73 (2001), 5822-5832.
 Posner, J. D. and Santiago, J. D., *J. Fluid. Mech.*, 555 (2006), 1-42.
 Shin, S. M. et al., *J. Micromech. Microeng.*, 15 (2005), 445-462.
 Sugii, Y. et al., *J. Visualization*, 8-2 (2005), 117-124.
 Yang, H. C., *J. Visualization*, 10-1 (2007), 83-90.